



Metalbilt Steel Roller Shutters

Applications

Factories, warehouses, industrial buildings, car parks, shop fronts or for any opening that must be securely and reliably closed.

Features

- Curtains are constructed from individually roll formed replaceable interlocking slats for additional strength.
- Shutters can be supplied with windlocked guides to help retain the curtain in excessive wind conditions and for increased security.
- Operation by motorised gearbox drive, manual hand chain or spring balance.
- Fixed, sliding and hinged mullions and wicket gate options are available.
- An extensive range of powder coating colours can be offered along with Zinalume coatings.
- Shutters are custom made to fit the size of opening and structure of building.
- Sales Asia Oceania wide.
- Branches in Auckland, Wellington and Christchurch.

**50 years of manufacturing experience and continuous refinement.
Service and repairs, 24 hours a day, on all makes of commercial doors.**

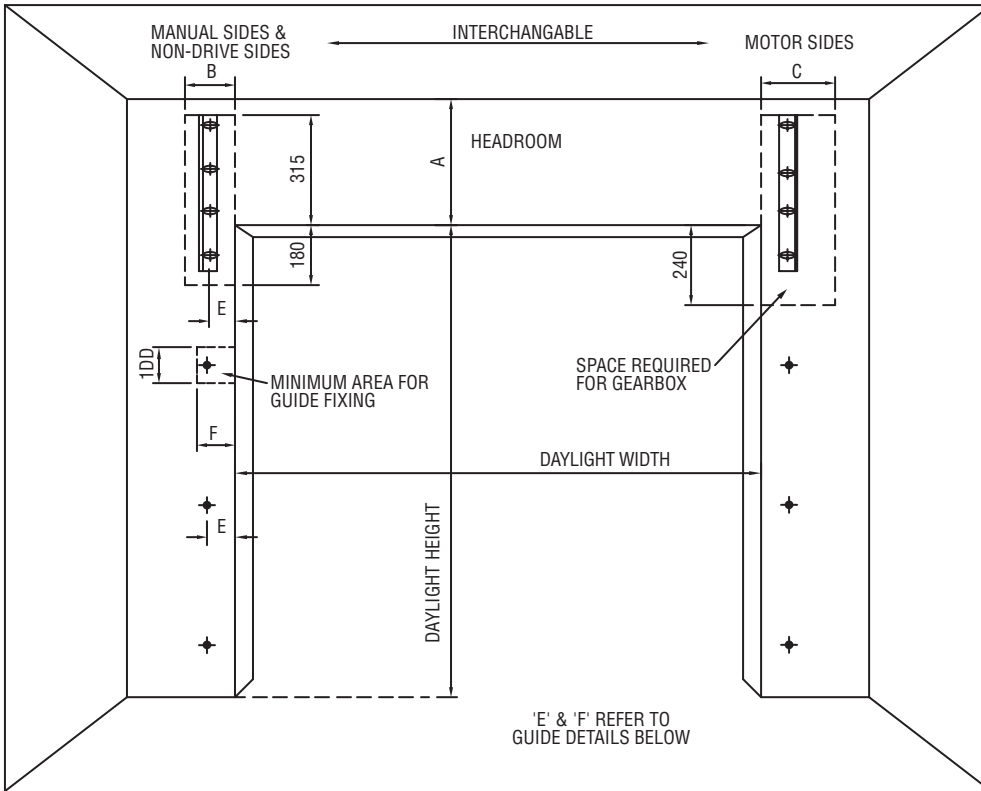

STEEL ROLLER SHUTTER CLEARANCES

| HEIGHT OF OPENING (m) | HEAD ROOM A | STANDARD GUIDE ² | | WINDLOCKED GUIDE ² | | INSIDE PROJECTION MANUAL D | INSIDE PROJECTION MOTORISED ³ D |
|--------------------------|----------------|-----------------------------|-----------------|-------------------------------|-----------------|-------------------------------|---|
| | | Non-Drive & Manual B | Motor Side C | Non-Drive & Manual B | Motor Side C | | |
| Up to 4.0 | 450 | 145 | 215 | 190 | 260 | 400 | 550 |
| Up to 4.5 | 450 | 145 | 215 | 190 | 260 | 430 | 580 |
| Up to 5.0 | 465 | 145 | 215 | 190 | 260 | 430 | 580 |
| Up to 6.0 | 475 | 145 | 215 | 190 | 260 | - | 580 |
| Up to 7.5 | 600 | 180 | 310 | 225 | 350 | - | 650 |

Note: 1 Extra headroom required for mullion doors.
 Note: 2 Low Sideroom options are available. Doors over 45m² require greater sideroom.
 Note: 3 Brake motor 615mm projection if required.

— BOLT LAYOUT SHEETS ARE AVAILABLE FROM METALBILT BRANCHES
 — STANDARD LAYOUT SHOWN. REFER TO METALBILT FOR SPECIAL CLEARANCE OPTIONS

CURTAIN

Assembled from roll formed, galvanised steel interlocked slats, each having an effective width of 100mm. The slats can be replaced individually if damaged. Ventilation slots optional.

BOTTOM BAR

Fitted to the lower edge of the curtain is an extruded aluminium bottom bar with a Neoprene weather strip.

GUIDES

Constructed from roll-formed galvanised steel. Standard guides have a depth of 50mm and fitted with adequate bell mouths to accept the shutter curtain. Windlocked guides 95mm deep, are recommended for wider openings or where higher security is required.

BARREL

Shutter barrels are fabricated from mild steel tube with a minimum diameter of 165mm and of sufficient wall thickness to ensure that nominal deflection does not exceed safe working conditions. Helically wound counterbalance springs are contained within the barrel.

MANUAL OPERATION

Manual operation is by hand chain, driving steel sprockets and 12.7mm pitch roller chain connected to a spring assisted barrel. Manually operated doors can easily be motorised at a later date if required. Spring Balanced operation is available on smaller size shutters.

ELECTRICAL OPERATION

The compact motorising units are powered by a 3 phase 0.37kW electric motor, driving an enclosed worm gearbox with chain reduction to the shutter barrel. Assemblies are supplied complete with reversing starter and limit switches. Standard speed of operation is approximately 200mm per second. Doors over 6m high operate at a reduced rate. Single phase is available. For high cycle or very large doors higher rated motors can be supplied. Door controllers that accept signals from a range of electronic and electrical equipment are also available. Special motorising options and barrel mounting methods are available on request.

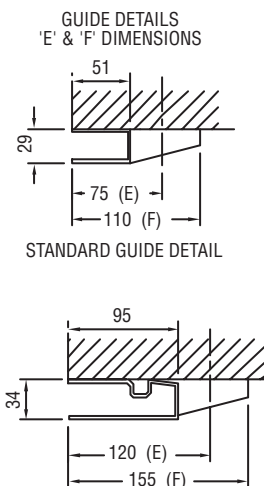
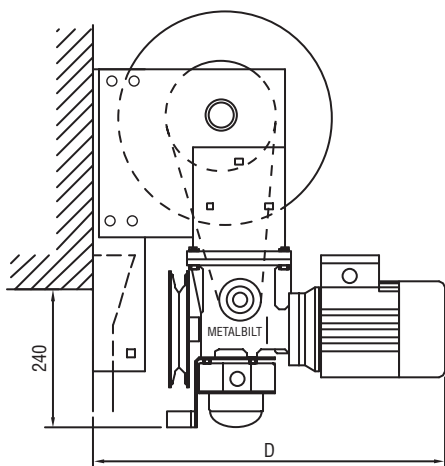

Standard doors meet the 5 year durability requirements of the N.Z.B.C. Details available on request

We reserve the right to alter specification without notice and without incurring obligation



Auckland

PO Box 71 169 Rosebank
 26 Timothy Place, Avondale
 Telephone: 09 828 1167
 Fax: 09 828 6358
 mbilt.auck@tycoint.com

Wellington

PO Box 38 933 W.M.C
 55 Cuba Street, Petone
 Telephone: 04 568 2933
 Fax: 04 568 7337
 mbilt.well@tycoint.com

Christchurch

PO Box 6033, Upper Riccarton
 60 Lunns Roads, Middleton
 Telephone: 03 338 2600
 Fax: 03 338 4386
 mbilt.chch@tycoint.com