



12mm Tube Aluminium Rolling Grilles

Applications

Bar tops, counter tops, shop fronts, pedestrian openings, arcades or anywhere that requires a high level of visibility and finish.

Features

- Curtains are constructed from individual 12mm diameter aluminium tubes connected with black nylon links.
- Operation by spring balance or motorised.
- Fixed or removable mullions options are available.
- An extensive range of powder coating colours can be offered.
- Grilles are custom made to fit the size of opening and structure of building.
- Sales Asia Oceania wide.
- Branches in Auckland, Wellington and Christchurch.

50 years of manufacturing experience and continuous refinement.
Service and repairs, 24 hours a day, on all makes of commercial doors.

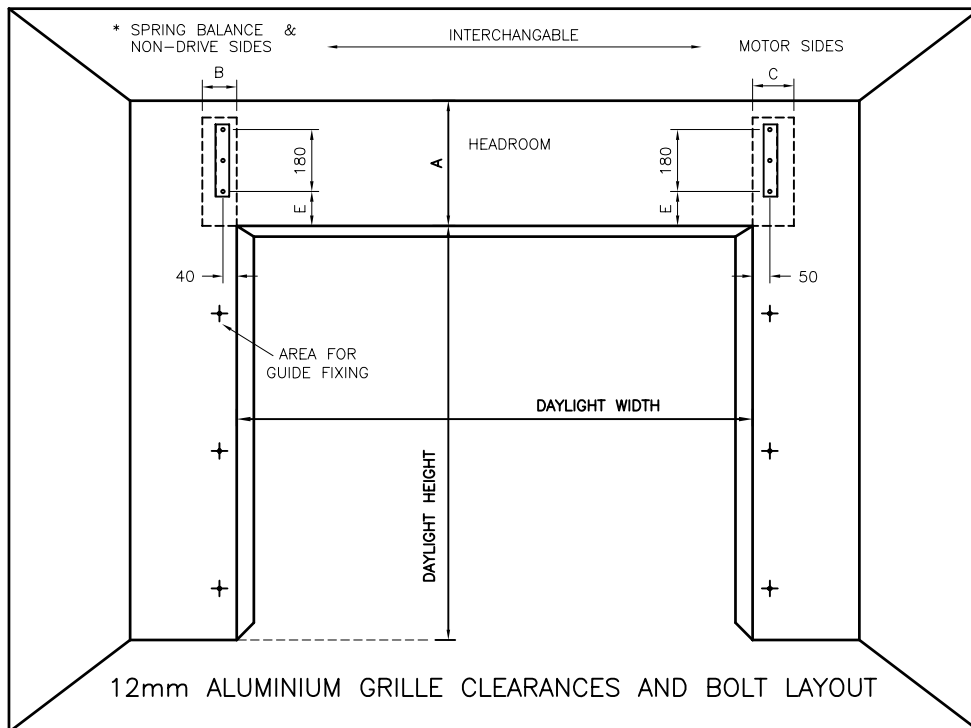

HEIGHT OF OPENING (m)	HEAD ROOM A	SIDEROOM * Non-Drive & Manual B	REQUIRED Motor Side C	INSIDE PROJECTION MANUAL D	INSIDE PROJECTION MOTORIZED D	BOTTOM FIXING POINT E	GUIDE PACKER SIZE F
Up to 1.25	370	110	120	360	550	90	0
Up to 2.0	400	110	120	400	580	100	0
Up to 3.0	450	110	120	460	605	115	40
Up to 4.0	500	110	120	-	615	140	50

* Low sideroom option minimum 65mm – Refer to factory
 Maximum Manual Size = 3.5m High x 4m Wide
 Maximum Motorised Size = 4m High x 5.5m Wide

SPRING BALANCE & NON-DRIVE SIDES

MOTOR SIDES

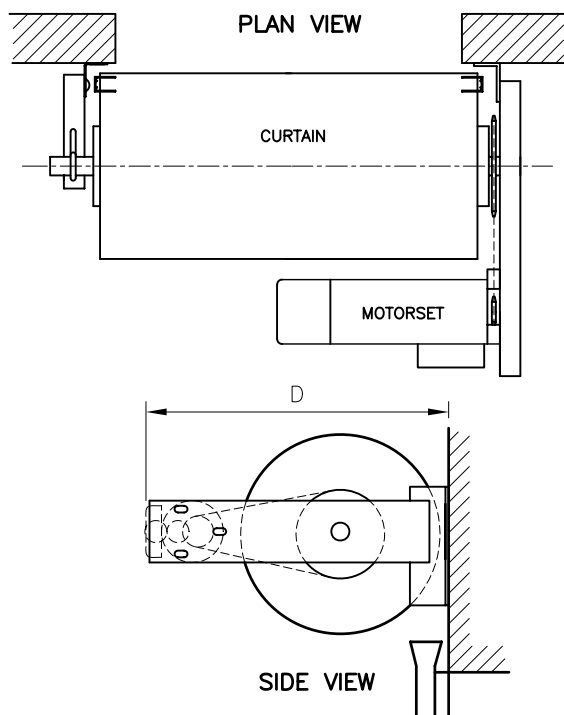

GUIDE DETAILS

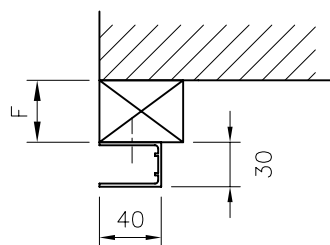

FACE FIX

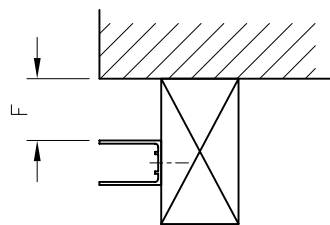

BACK FIX

CURTAIN

Assembled from 12mm aluminium tubes and moulded nylon links into a brick pattern. The tubes and links can be replaced individually if damaged. Fitted to the lower edge of the curtain is an extruded aluminium bottom bar.

GUIDES

Specially extruded aluminium channel 40mm x 30mm. Guides screwed to jambs at max. 600mm centres. Each guide is constructed with a bell mouth to facilitate smooth entry of the curtain.

FINISH

Clear anodised or powder coated.

BARREL

Grille barrels are fabricated from mild steel tube with a minimum diameter of 165mm and of sufficient wall thickness to ensure that nominal deflection does not exceed safe working conditions. Helically wound counterbalance springs are contained within the barrel.

SECURITY

Flush mounted lock with various keying options.

OPERATION

Spring balanced or motorised. Motorised grilles have single phase motorsets with adjustable limit switches and control pendant. Operating speed is approximately 170mm per second. The motorsets incorporate an automatically engaging handchain for use during power failures. Battery backup systems are available.

Key switches and door controllers that accept signals from a range of electronic and electrical equipment are also available. Special motorising options and barrel mounting methods are available on request.

Standard doors meet the 5 year durability requirements of the N.Z.B.C. Details Available on request.

We reserve the right to alter specification without notice and without incurring obligation



Auckland
 PO Box 71 169 Rosebank
 26 Timothy Place, Avondale
 Telephone: 09 828 1167
 Fax: 09 828 6358
 mbilt.auck@metalbilt.co.nz

Wellington
 PO Box 38 933 W.M.C
 55 Cuba Street, Petone
 Telephone: 04 568 2933
 Fax: 04 568 7337
 mbilt.well@metalbilt.co.nz

Christchurch
 PO Box 6033, Upper Riccarton
 60 Lunns Roads, Middleton
 Telephone: 03 338 2600
 Fax: 03 338 4386
 mbilt.chch@metalbilt.co.nz